

PICKET FLOWER BOX

With ProWood® Professional Grade pressure-treated lumber, enhance and add beauty to your yard or deck with a picket flower box. This flower box goes together so quickly, you may be inspired to build several.

Materials

- Eight 1" x 2" x 8' ProWood® Pressure-Treated Boards
- One Box 1-1/4" 4d Galvanized Finish Nails

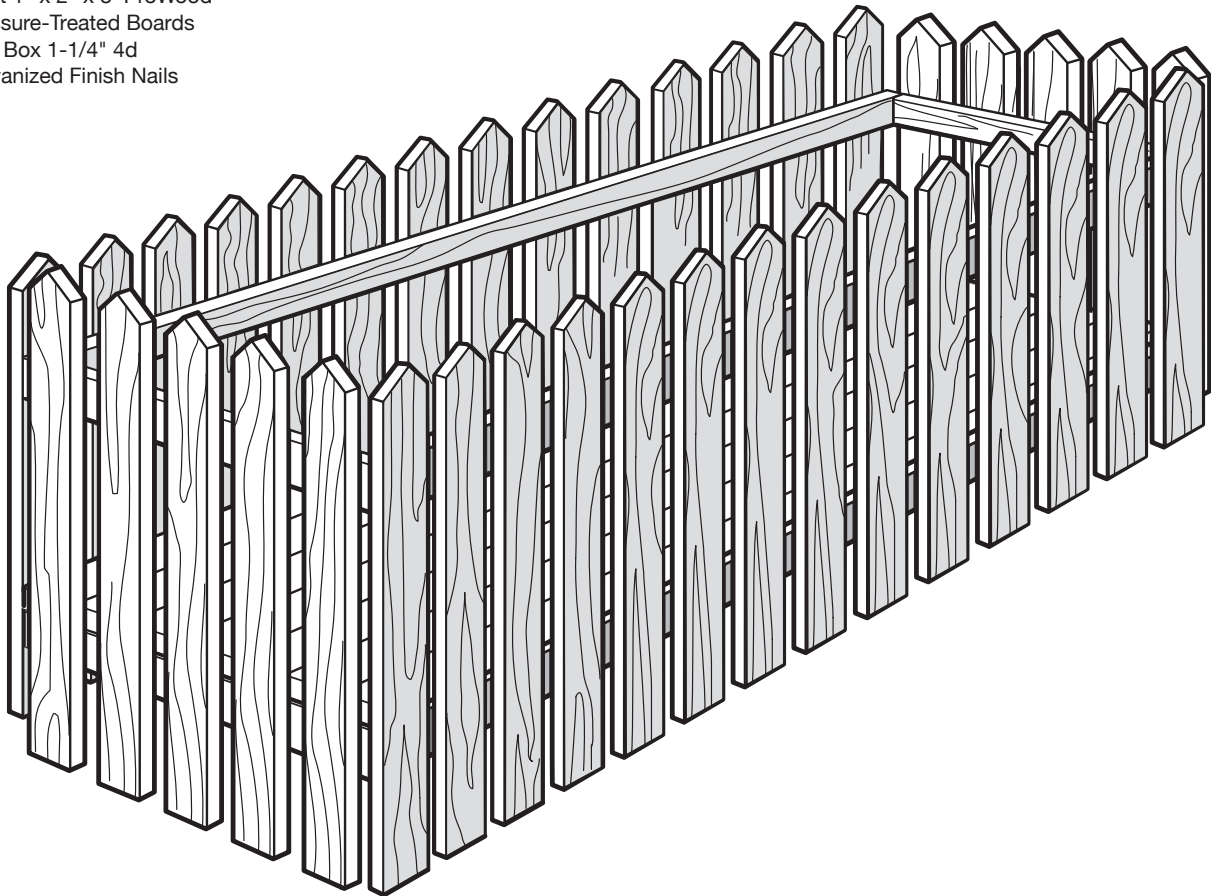

Basic Tools

- Miter Box or Angle Square for Angle Cuts
- Circular Power Saw
- Tape Measure
- Hammer

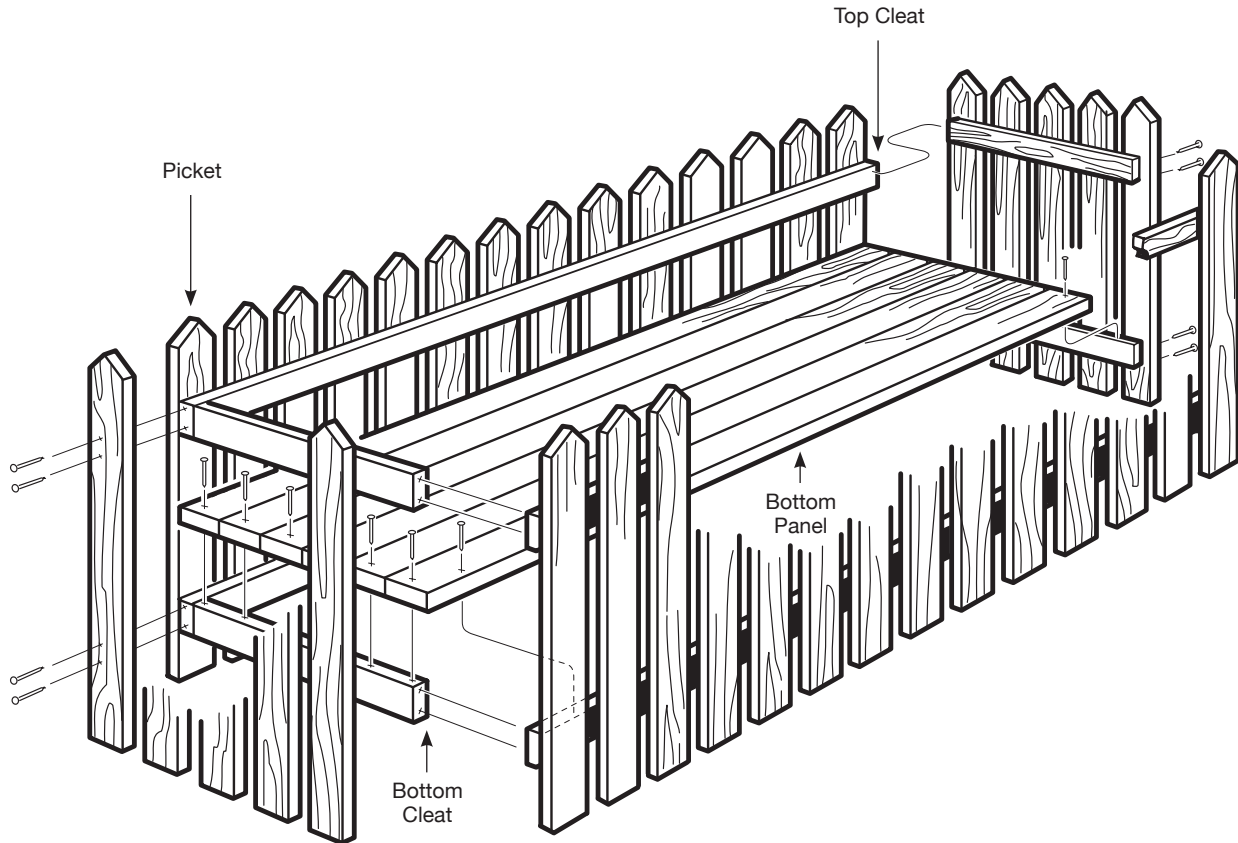

Cut the Lumber to Size

Caution: Always wear gloves, a dust mask and eye protection when sawing, sanding or machining wood.

Using a circular saw, cut the boards for the picket flower box.

- Start by cutting five 1" x 2" x 8' ProWood® boards into thirty-eight 10-1/2" sections. These will become the pickets for the sides of the box.
- Cut one of the 1" x 2" x 8' ProWood® boards into four 23" cleats for the front and back panels.
- Cut two 1" x 2" x 8' ProWood® boards into six 23" pieces for the floor of the flower box.
- You will have a 48" piece left over. Cut the 48" piece into four 7-1/2" cleats. The 7-1/2" cleats will hold together the two side panels.

Cut the Picket Tops

- Using a tape measure, find and mark the center of one end of each of the thirty-eight 10-1/2" side pieces.
- Using an angle square, draw 45-degree angle marks to each side from the top center of each piece.
- Cut along the marks using a miter saw or circular saw.

Build the Front and Back Panels

You will use two 23" cleats and fourteen pickets to build the front panel of the flower box. The pickets and the cleats will be attached by nailing from the inside, through the cleat and into the pickets.

- Start by marking lines across all fourteen pickets 2" from the top and 1-1/4" from the bottom. The 2" mark will align with the top edge of the top cleat. The 1-1/4" mark will align with the bottom edge of the bottom cleat.
- Refer to the illustration at the top of the following page.
- Lay the fourteen pickets flat on the ground, side by side, with the pointed picket tops pointing away from you. Going from left to right, label the pickets #1 through #14. Use a pencil so you can erase the numbers later. Measure 10-5/8" in from both ends of the top and bottom cleats. Make a mark.
- Place the two outermost pickets (#1 and #14) under the top and bottom cleats so the outside edge of the pickets are flush with the outside edges of the cleats. Make sure the line drawn 2" from the top of the picket aligns with the top edge of the cleat and the line drawn 1-1/4" from the bottom of the pickets aligns with the bottom edge of the cleat.
- Place pickets #7 and #8 centered on the two 10-5/8" marks at the middle of the cleats.
- Use 1-1/4" 4d galvanized finish nails to attach the cleats to pickets #1, #7, #8 and #14.
- Measure and mark the halfway point between pickets #1 and #7 and pickets #8 and #14.
- Attach pickets #5 and #11 to the cleats, each centered on their own mark.
- Finally, attach two pickets, evenly spaced, in each of the gaps that remain.
- While building the front panel, keep in mind which side of the wood will face outward. You want to keep its "best" side visible.
- Repeat these steps to build the back panel of the flower box.

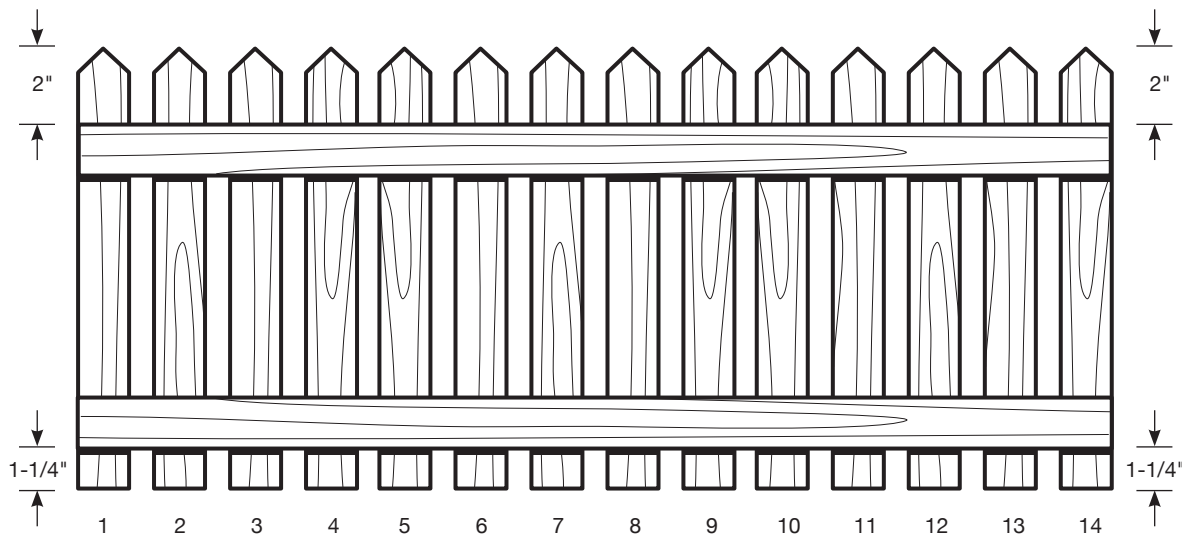

Build the Side Panels

- Use two 7-1/2" cleats and five pickets to assemble each side of the flower box. As with the front and back panels, the bottom cleat should be 1-1/4" from the bottom of the side and the top cleat should be 2" below the top of the pickets.
- Attach the two outermost pickets to the top and bottom cleats, making sure the pickets overhang the ends of the cleats by 5/8" on either side of the panel.
Refer to the illustration on the right.
- Measure and mark the midpoint between the outer pickets and attach a third picket centered on the mark.
- Attach two more pickets to the side, evenly spaced between the center and outer pickets. Again, use 1-1/4" nails and keep in mind which side of the wood will be visible on the outside of the flower box.

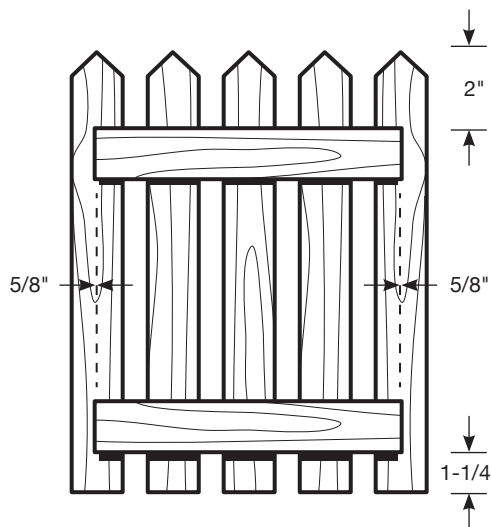

Put the Three Sides Together

- Place the side panels at each end of the front section so that they form three sides of the box.
- Using 1-1/4" 4d galvanized finish nails, attach the side panels to the front panel by nailing through from the outside face of the side panel into the edge of the front panel cleats.
Refer to the illustration on the previous page.

Make the Box Bottom

- Take the six 23" bottom pieces and slot them one-by-one into the three attached flower box sides so that they rest flat on the bottom cleats. The bottom pieces will ensure that the structure is square.

Put on the Back Panel

- Place the back panel against the three attached sides so that the bottom cleat on the back panel slides under the bottom board and the panel butts up against the edges of the side panels.
- Attach the back panel to the sides by nailing through from the outside face of the side panels into the edge of the back panel cleats.
- Nail the bottom boards to the bottom cleats.

This brochure is for illustration purposes only. Use of this product must be in accordance with all local zoning and/or building codes. Consumer assumes all risks and liability associated with the use of this product. For details on safe handling, go to UFPI.com/ptinfo. Warrantor does not provide any warranty, either express or implied, and shall not be liable for any damages, including consequential damages. 7094 07/13